

Instructions

Tektronix

**P2200 200 MHz
1X/10X Passive Probe**

071-1102-00



071110200

Copyright © Tektronix, Inc. All rights reserved.

Tektronix products are covered by U.S. and foreign patents, issued and pending. Information in this publication supercedes that in all previously published material. Specifications and price change privileges reserved.

Tektronix, Inc., P.O. Box 500, Beaverton, OR 97077

TEKTRONIX and TEK are registered trademarks of Tektronix, Inc.

WARRANTY

Tektronix warrants that the products that it manufactures and sells will be free from defects in materials and workmanship for a period of one (1) year from the date of shipment. If a product proves defective during this warranty period, Tektronix, at its option, either will repair the defective product without charge for parts and labor, or will provide a replacement in exchange for the defective product.

In order to obtain service under this warranty, Customer must notify Tektronix of the defect before the expiration of the warranty period and make suitable arrangements for the performance of service. Customer shall be responsible for packaging and shipping the defective product to the service center designated by Tektronix, with shipping charges prepaid. Tektronix shall pay for the return of the product to Customer if the shipment is to a location within the country in which the Tektronix service center is located. Customer shall be responsible for paying all shipping charges, duties, taxes, and any other charges for products returned to any other locations.

This warranty shall not apply to any defect, failure or damage caused by improper use or improper or inadequate maintenance and care. Tektronix shall not be obligated to furnish service under this warranty a) to repair damage resulting from attempts by personnel other than Tektronix representatives to install, repair or service the product; b) to repair damage resulting from improper use or connection to incompatible equipment; c) to repair any damage or malfunction caused by the use of non-Tektronix supplies; or d) to service a product that has been modified or integrated with other products when the effect of such modification or integration increases the time or difficulty of servicing the product.

THIS WARRANTY IS GIVEN BY TEKTRONIX IN LIEU OF ANY OTHER WARRANTIES, EXPRESS OR IMPLIED. TEKTRONIX AND ITS VENDORS DISCLAIM ANY IMPLIED WARRANTIES OF MERCHANTABILITY OR FITNESS FOR A PARTICULAR PURPOSE. TEKTRONIX' RESPONSIBILITY TO REPAIR OR REPLACE DEFECTIVE PRODUCTS IS THE SOLE AND EXCLUSIVE REMEDY PROVIDED TO THE CUSTOMER FOR BREACH OF THIS WARRANTY. TEKTRONIX AND ITS VENDORS WILL NOT BE LIABLE FOR ANY INDIRECT, SPECIAL, INCIDENTAL, OR CONSEQUENTIAL DAMAGES IRRESPECTIVE OF WHETHER TEKTRONIX OR THE VENDOR HAS ADVANCE NOTICE OF THE POSSIBILITY OF SUCH DAMAGES.

Contacting Tektronix

Phone	1-800-833-9200*
Address	Tektronix, Inc. Department or name (if known) 14200 SW Karl Braun Drive P.O. Box 500 Beaverton, OR 97077 USA
Web site	www.tektronix.com
Sales support	1-800-833-9200, select option 1*
Service support	1-800-833-9200, select option 2*
Technical support	Email: techsupport@tektronix.com 1-800-833-9200, select option 3* 6:00 a.m. - 5:00 p.m. Pacific time

* **This phone number is toll free in North America. After office hours, please leave a voice mail message. Outside North America, contact a Tektronix sales office or distributor; see the Tektronix web site for a list of offices.**

General Safety Summary

Review the following safety precautions to avoid injury and prevent damage to this product or any products connected to it. To avoid potential hazards, use this product only as specified.

Only qualified personnel should perform service procedures.

Connect and Disconnect Properly. Connect the probe output to the measurement instrument before connecting the probe to the circuit under test. Disconnect the probe input and the probe ground from the circuit under test before disconnecting the probe from the measurement instrument.

Observe All Terminal Ratings. To avoid fire or shock hazard, observe all ratings and markings on the product. Consult the product manual for further ratings information before making connections to the product.

Do not Operate Without Covers. Do not touch exposed connections and components when power is present.

Avoid Exposed Circuitry. Do not touch exposed connections and components when power is present.

Do Not Operate With Suspected Failures. If you suspect there is damage to this product, have it inspected by qualified service personnel.

Do Not Operate in Wet/Damp Conditions.

Do Not Operate in an Explosive Atmosphere.

Keep Product Surfaces Clean and Dry.

Safety Terms and Symbols

Terms in This Manual. These terms may appear in this manual:



WARNING. *Warning statements identify conditions or practices that could result in injury or loss of life.*



CAUTION. *Caution statements identify conditions or practices that could result in damage to this product or other property.*

Terms on the Product. These terms may appear on the product:

DANGER indicates an injury hazard immediately accessible as you read the marking.

WARNING indicates an injury hazard not immediately accessible as you read the marking.

CAUTION indicates a hazard to property including the product.

Symbols on the Product. These symbols may appear on the product:



CAUTION
Refer to Manual



WARNING
High Voltage



Protective Ground
(Earth) Terminal

P2200 Passive Probe

The P2200 200 MHz 1X/10X Passive Probe is a compact passive probe with selectable 1X/10X attenuation. The probe is designed for use with Tektronix TDS1000/2000 Series oscilloscopes with input capacitances between 15 and 25 pF. This probe has no user-serviceable or Tektronix-serviceable parts.

Features and Accessories

Table 1 shows the features and accessories of the P2200 probe. To replace an accessory, use the Tektronix replacement part number provided in the description column.

Table 1: Features and standard accessories



Feature/Accessory	Description
 <p>1 X  10 X</p>	<p>Probe attenuation. This switch selects the attenuation factor of the probe.</p>
 <p>Hook tip</p>	<p>Hook tip. Connects the probe tip to wires and component leads for hands-free measurement.</p> <p>NOTE. For a solid connection, firmly push and twist the hook tip onto the probe tip before using.</p> <p>Tektronix part number: 013-0318-XX</p>
 <p>Color marker bands</p>	<p>Color marker bands. Attach matching pairs of the color marker bands onto the strain-relief sections of cable at the probe head and compensation box. When several probes are connected to an instrument, the color marker bands enable quick verification of which probe is connected to which instrument channel.</p> <p>Tektronix part number: 016-1315-XX, two each of five colors</p>

Table 1: Features and standard accessories (Cont.)

Feature/Accessory	Description
	<p>Ground lead. Use the ground lead for connecting the probe ground to the circuit.</p> <p>Tektronix part number: 196-3466-XX</p>
	<p>Adjustment tool. Used to adjust probe compensation. Access the adjustment through the opening near the BNC connector.</p> <p>Tektronix part number: 003-1873-XX</p>
	<p>Instructions. Provides instructions for operating the probe.</p> <p>Tektronix part number: 071-1102-XX</p>
 <p data-bbox="276 1144 414 1176">Finger guard</p>	<p>Guard. Keeps fingers away from the probe tip for protection against electric shock.</p>

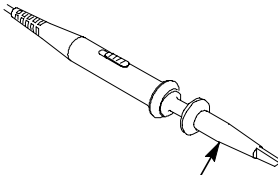
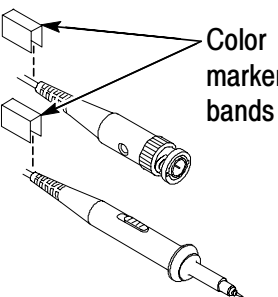
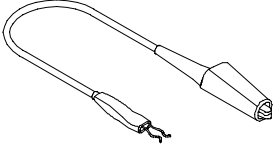
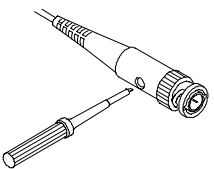
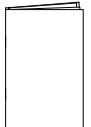
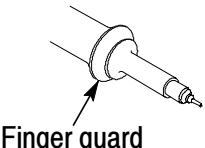

WARNING. *To avoid electric shock when using the probe, keep fingers behind the guard on the probe body.*

Probe Compensation

Due to variations in oscilloscope input characteristics, probe low-frequency compensation may need adjustment after moving the probe from one oscilloscope to another. If a 1 kHz calibrated square wave displayed at 1 ms/division shows significant differences between the leading and trailing edges, perform the following steps to optimize low-frequency compensation.

1. Connect the probe to the calibration signal on the oscilloscope front panel.
2. Press **AUTOSET** or otherwise adjust your digitizing oscilloscope to display a meaningful waveform.
3. Adjust the trimmer in the probe until you see a perfectly flat-top square wave on the display. See Figure 1.

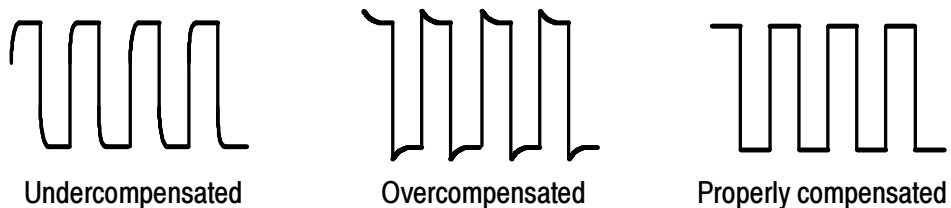

Figure 1: Probe compensation waveforms

Specifications

Table 2: Electrical characteristics

	10X position	1X position
Bandwidth	DC to 200 MHz	DC to 6 MHz
System Attenuation Accuracy	10:1± 2%	1:1± 2%
Compensation Range	15 pF-25 pF	—
System Input Resistance	10 MΩ ± 3% at DC	1 MΩ ± 3% at DC
System Input Capacitance	13.0 pF-17.0 pF	80 pF-110 pF
System Risetime (typical)	<2.2 ns	<50 ns
Maximum input voltage ¹	10X position	300 V _{RMS} CAT I or 300 V DC CAT I 300 V _{RMS} CAT II or 300 V DC CAT II 100 V _{RMS} CAT III or 100 V DC CAT III 420 V peak, <50% DF, <1 s PW 670 V peak, <20% DF, <1 s PW
	1X position	150 V _{RMS} CAT I or 150 V DC CAT I 150 V _{RMS} CAT II or 150 V DC CAT II 100 V _{RMS} CAT III or 100 V DC CAT III 210 V peak, <50% DF, <1 s PW 330 V peak, <20% DF, <1 s PW

¹ As defined in EN61010-1. See Certifications and compliances in Table 3.

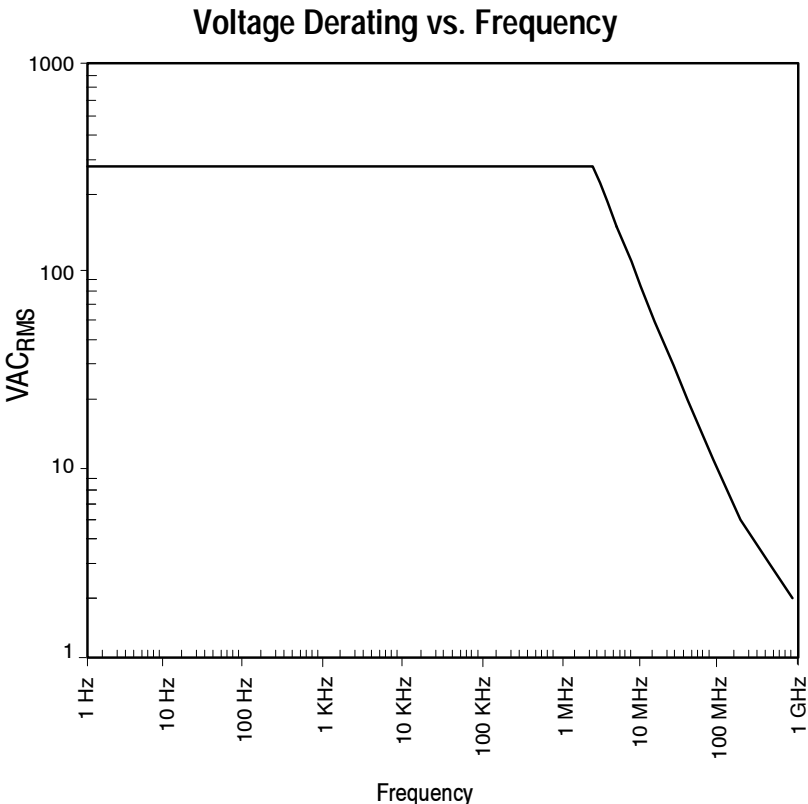

Figure 2: Derating curve for determining maximum input voltage

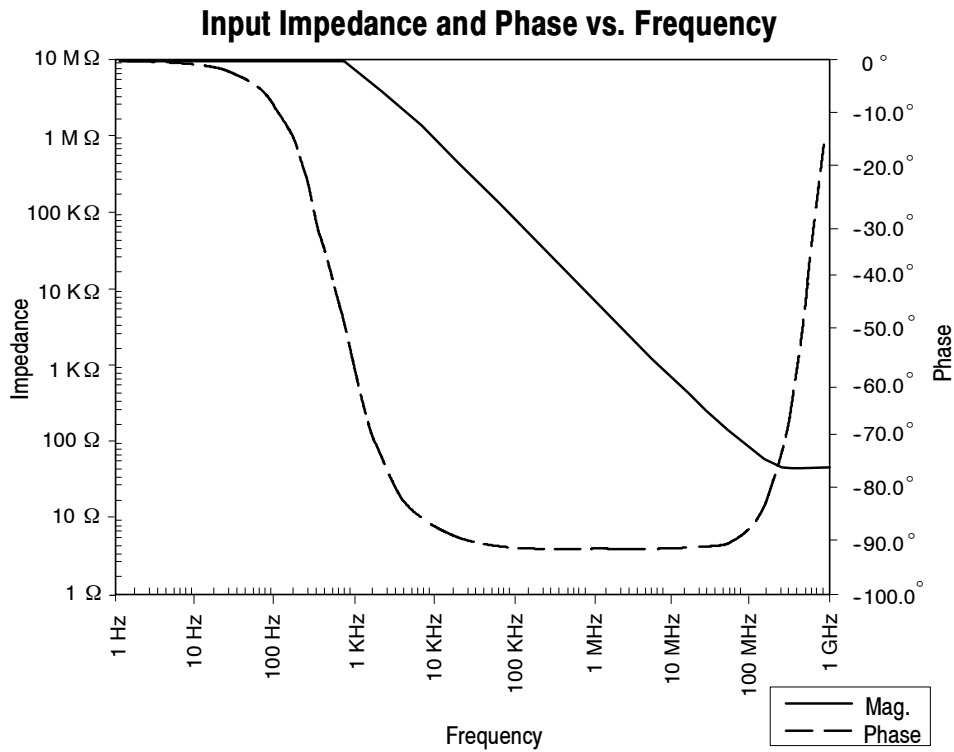

Figure 3: P2200 Input impedance and phase vs. frequency graph

Table 3: Certifications and compliances

<p>EC Declaration of Conformity</p>	<p>Compliance was demonstrated to the following specification as listed in the Official Journal of the European Communities:</p> <p>Low Voltage Directive 73/23/EEC as amended by 93/68/EEC:</p> <p>EN 61010-1/A2 Safety requirements for electrical equipment for measurement, control, and laboratory use</p> <p>EN61010-2-031: 1994 Particular requirements for hand-held probe assemblies for electrical measurement and test</p>
<p>Overvoltage Category</p>	<p>Category: Examples of Products in this Category:</p> <p>CAT III Distribution-level mains, fixed installation</p> <p>CAT II Local-level mains, appliances, portable equipment</p>

Table 3: Certifications and compliances (Cont.)

	CAT I	Signal levels in special equipment or parts of equipment, telecommunications, electronics
Pollution Degree 2	Do not operate in environments where conductive pollutants may be present.	
Safety	UL3111-1, First Edition & UL3111-2-031, First Edition CSA C22.2 No. 1010.1-92 & CAN/CSA C22.2 No. 1010.2.031-94 IEC61010-1/A2 IEC61010-2-031 Pollution Degree 2	

Table 4: Environmental characteristics

Temperature	Operating	32° F - 122° F (0° C - +50° C)
	Nonoperating	-40° F - 159.8° F (-40° C - +71° C)
Cooling Method	Convection	
Humidity	+104° F (+40° C) or below	≤ 90% relative humidity
	+104° F - 122° F (+40° C - +50° C)	≤ 60% relative humidity
Altitude	Operating	10,000 ft (3,000 m)
	Nonoperating	40,000 ft (15,000 m)

